



# CRAZY TAXI™



TEEN™

T

CONTENT RATED BY  
ESRB

51035

SEGA®



# **WARNINGS Read Before Using Your Sega Dreamcast Video Game System**

## **CAUTION**

Anyone who uses the Dreamcast should read the operating manual for the software and console before operating them. A responsible adult should read these manuals together with any minors who will use the Dreamcast before the minor uses it.

## **HEALTH AND EPILEPSY WARNING**

Some small number of people are susceptible to epileptic seizures or loss of consciousness when exposed to certain flashing lights or light patterns that they encounter in everyday life, such as those in certain television images or video games. These seizures or loss of consciousness may occur even if the person has never had an epileptic seizure.

If you or anyone in your family has ever had symptoms related to epilepsy when exposed to flashing lights, consult your doctor prior to using Sega Dreamcast.

In all cases, parents should monitor the use of video games by their children. If any player experiences dizziness, blurred vision, eye or muscle twitches, loss of consciousness, disorientation, any involuntary movement or convulsion, **IMMEDIATELY DISCONTINUE USE AND CONSULT YOUR DOCTOR BEFORE RESUMING PLAY.**

To reduce the possibility of such symptoms, the operator must follow these safety precautions at all times when using Dreamcast:

- Sit a minimum of 6.5 feet away from the television screen. This should be as far as the length of the controller cable.
- Do not play if you are tired or have not had much sleep.
- Make sure that the room in which you are playing has all the lights on and is well lit.
- Stop playing video games for at least ten to twenty minutes per hour. This will rest your eyes, neck, arms and fingers so that you can continue comfortably playing the game in the future.

## **OPERATING PRECAUTIONS**

To prevent personal injury, property damage or malfunction:

- Before removing disc, be sure it has stopped spinning.
- The Sega Dreamcast GD-ROM disc is intended for use exclusively on the Sega Dreamcast video game system. Do not use this disc in anything other than a Dreamcast console, especially not in a CD player.
- Do not allow fingerprints or dirt on either side of the disc.
- Avoid bending the disc. Do not touch, smudge or scratch its surface.
- Do not modify or enlarge the center hole of the disc or use a disc that is cracked, modified or repaired with adhesive tape.
- Do not write on or apply anything to either side of the disc.
- Store the disc in its original case and do not expose it to high temperature and humidity.
- Do not leave the disc in direct sunlight or near a radiator or other source of heat.
- Use lens cleaner and a soft dry cloth to clean disc, wiping gently from the center to the edge. Never use chemicals such as benzene and paint thinner to clean disc.

## **PROJECTION TELEVISION WARNING**

Still pictures or images may cause permanent picture tube damage or mark the phosphor of the CRT. Avoid repeated or extended use of video games on large-screen projection televisions.

## **SEGA DREAMCAST VIDEO GAME USE**

This GD-ROM can only be used with the Sega Dreamcast video game system. Do not attempt to play this GD-ROM on any other CD player; doing so may damage the headphones and/or speakers. This game is licensed for home play on the Sega Dreamcast video game system only. Unauthorized copying, reproduction, rental, public performance of this game is a violation of applicable laws. The characters and events portrayed in this game are purely fictional. Any similarity to other persons, living or dead, is purely coincidental.



Thank you for purchasing **Crazy Taxi™!**

Please note that this software is designed only for use with the Sega Dreamcast console. Be sure to read this instruction manual thoroughly before you start playing Crazy Taxi.



# CONTENTS

<b>BASIC CONTROLS</b>	<b>2</b>
<b>CRAZY MANEUVERING</b>	<b>4</b>
<b>MODE SELECTION MENU</b>	<b>5</b>
<b>ARCADE/ORIGINAL MODE</b>	<b>6</b>
<b>CRAZY BOX MODE</b>	<b>12</b>
<b>OPTIONS</b>	<b>15</b>
<b>RECORDS</b>	<b>16</b>
<b>SAVE &amp; LOAD</b>	<b>17</b>
<b>CABBIES</b>	<b>18</b>
<b>CUSTOMERS</b>	<b>20</b>

Crazy Taxi is a memory card compatible game [Visual Memory Unit (VMU) sold separately]. In order to save game files, the VMU to be used must have at least 23 memory blocks of free space available.



# BASIC CONTROLS

Crazy Taxi is a one-player game that can be played using either the Dreamcast Controller or the Rally Wheel (sold separately). Connect the controller to be used to Control Port A of the Dreamcast.



## Dreamcast Controller

**NOTE:** To soft-reset using the Dreamcast Controller and return to the title screen at any point during game play, simultaneously press and hold the A, B, X, Y and Start Buttons.

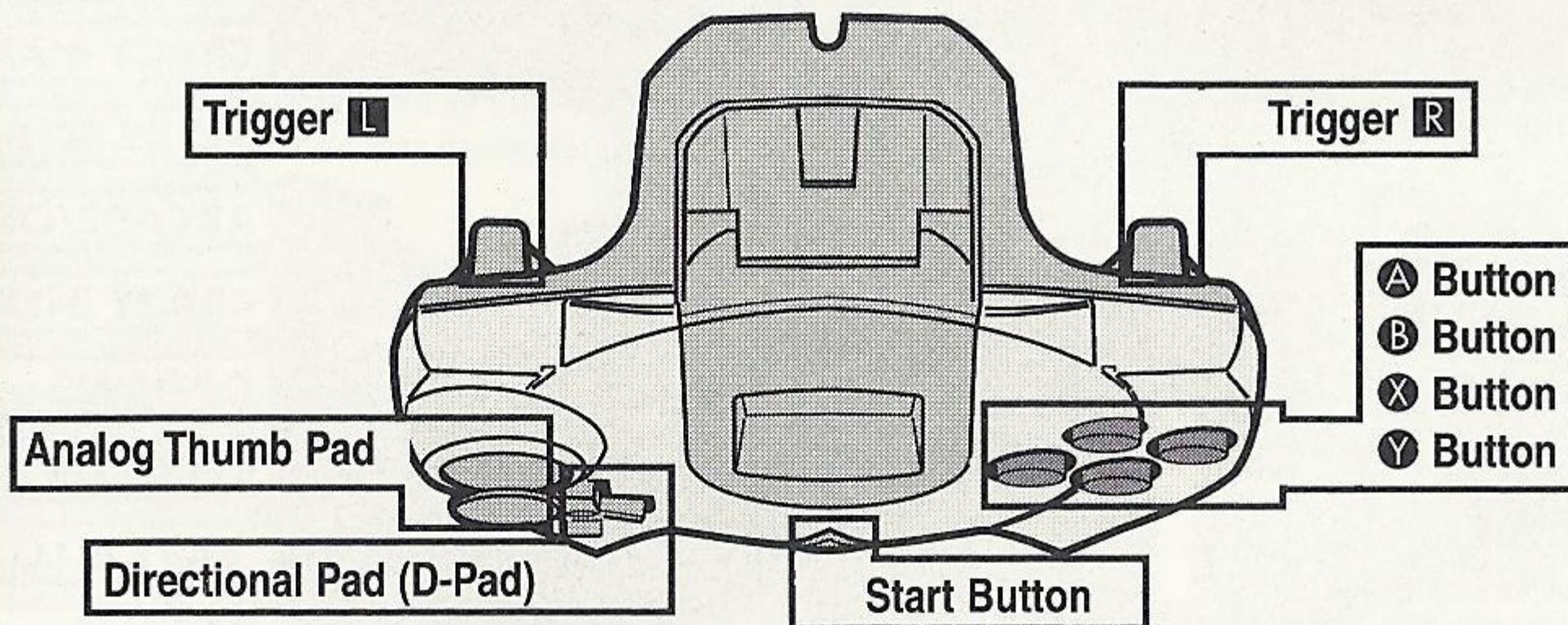

## Rally Wheel (sold separately)

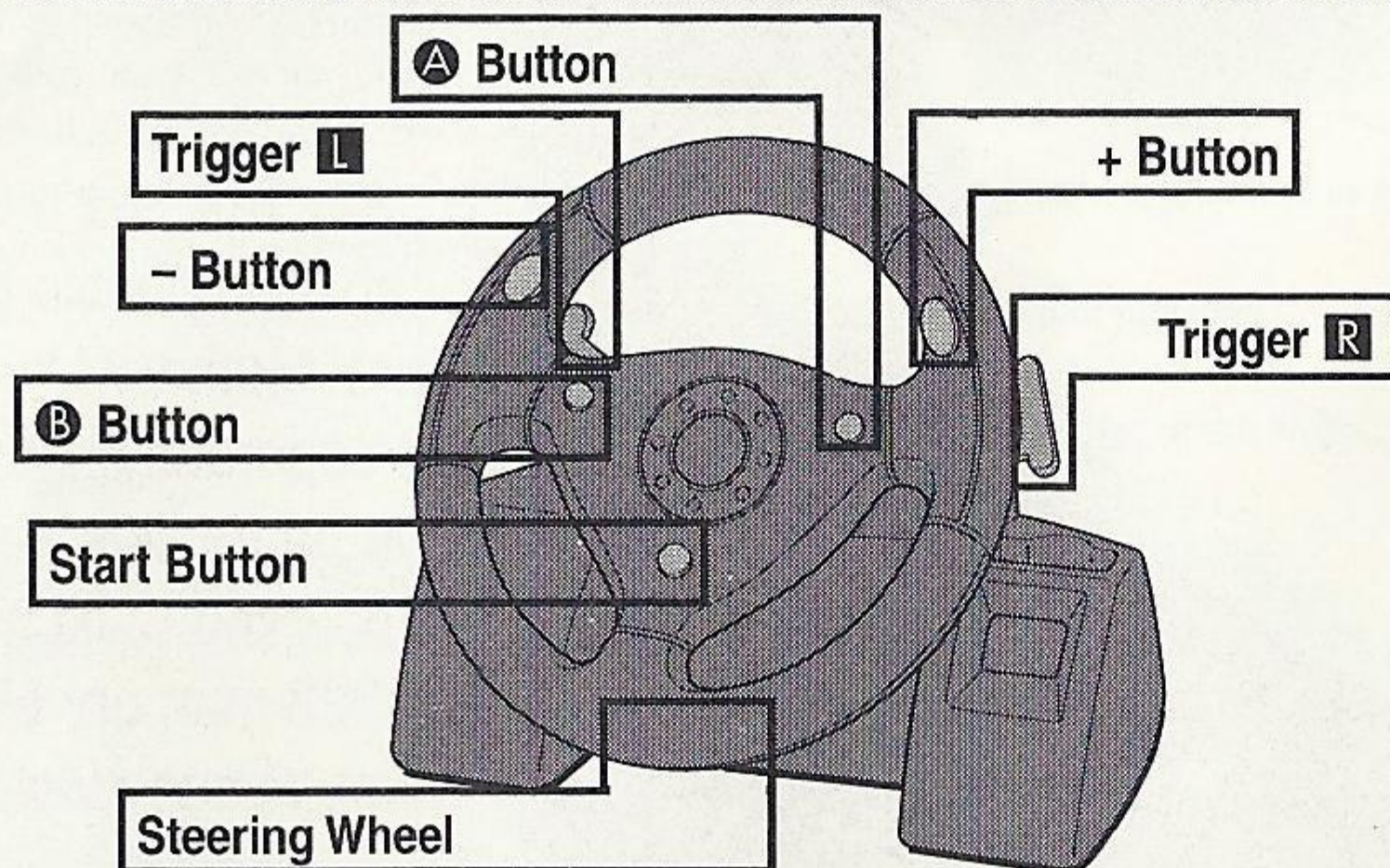

**NOTE:** To soft-reset using the Rally Wheel and return to the title screen at any point during game play, simultaneously press and hold the A, B and Start Buttons.



# BASIC CONTROLS

Refer to the following chart for a summary of the game controls:

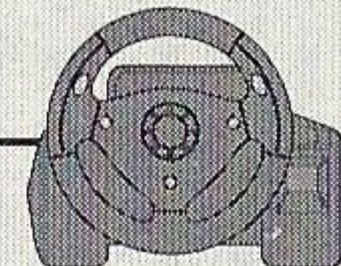
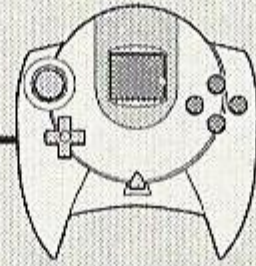

	Action or Command	Dreamcast Controller	Rally Wheel
During Menu Selection	Moving the Cursor Enter Cancel/Return to the Previous Screen Item Selection	Analog Thumb Pad/D-Pad A Button B Button ← →	+ / - Button A Button B Button Steering Wheel
During Game Play	Game Start/Pause Character Selection Steering Accelerating Braking Drive Gear Reverse Gear Destination Reminder	Start Button Analog Thumb Pad/D-Pad Analog Thumb Pad Trigger R Trigger L B Button A Button X Button	Start Button Steering Wheel Steering Wheel Trigger R Trigger L + Button - Button B Button

- The controls described in this instruction manual describe usage of the Dreamcast Controller except where specified as describing usage of the Rally Wheel.
- All button icons used in this instruction manual represent the default button settings.

**CAUTION:** Never touch the Analog Thumb Pad or the Triggers R/L (Rally Wheel = Steering Wheel, Triggers R/L) while turning the Dreamcast power ON. Doing so may disrupt the controller initialization procedure and result in malfunction.

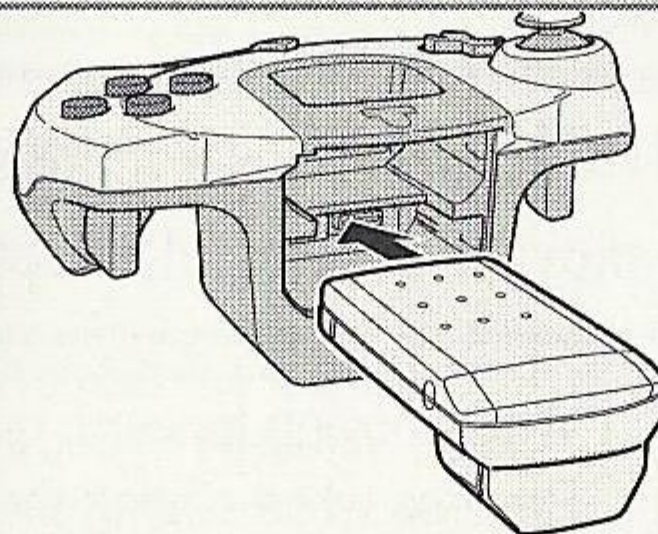

**Using the Jump Pack:**  
When using the Jump Pack (sold separately) while playing Crazy Taxi, always be sure to insert the Jump Pack into Expansion Socket 2 of the Dreamcast Controller.



# CRAZY MANEUVERING

Learn how to perform these crazy maneuvers using different combinations of the **Steering Wheel, Accelerator, Brake and Drive/Reverse Shifting** commands.

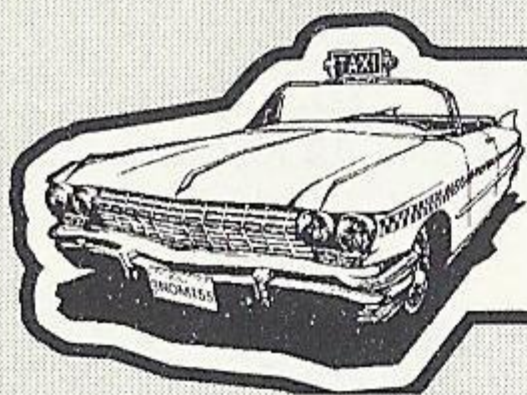

**CRAZY DASH** - Propel the cab forwards with a burst of speed with this crazy move.

## HOW TO EXECUTE

First, release both the accelerator and brake. Then, just after shifting into Drive, press the accelerator.



**CRAZY DRIFT** - Use this move to cause the cab to execute a sliding drift.

## HOW TO EXECUTE

While moving forward, quickly shift into Reverse and back into Drive while cutting the Steering Wheel to the right or left.



**CRAZY BACK DASH** - Execute a hasty retreat with this speedy thrust in reverse.

## HOW TO EXECUTE

Shift quickly into Reverse just after executing a **Crazy Dash**.

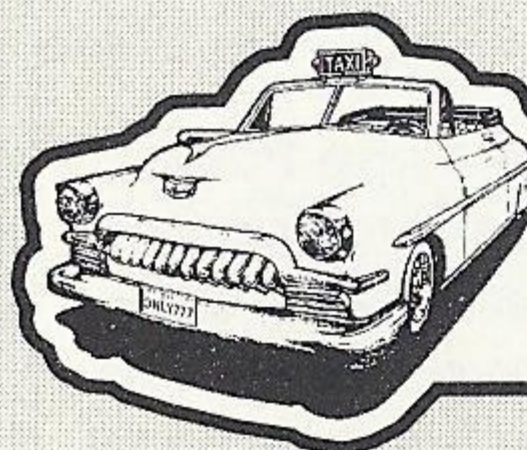

**CRAZY BACK DRIFT** - With this move the cab will continue to move in reverse after spinning 180°.

## HOW TO EXECUTE

While moving forward, quickly shift into Drive and back into Reverse while cutting the Steering Wheel to the right or left.



# MODE SELECTION MENU

Once the title screen appears, press the Start Button to display the mode selection menu. Use **↑** **↓** to select an item and press **A** to enter your selection.

Select **"EXIT"** or press **B** to return to the title screen. For details on each of the modes available, refer to the corresponding page numbers listed below.

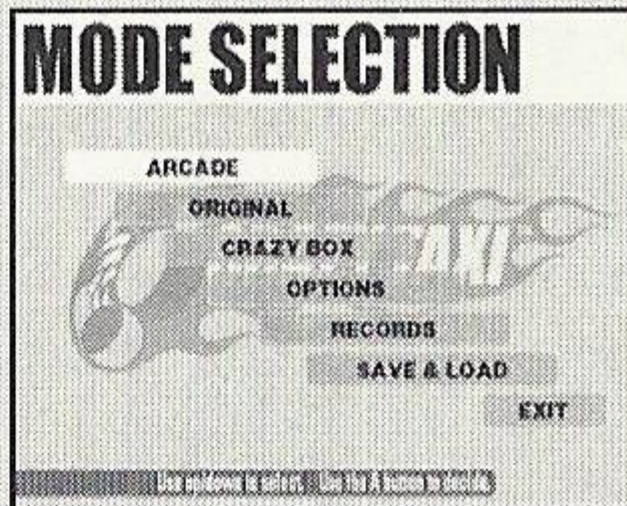

## ARCADE

p. 6

In this game mode, play using the same course as the one featured in the Arcade version of Crazy Taxi.

## ORIGINAL

p. 6

Select this game mode to play using the specially designed Dreamcast original course.

## CRAZY BOX

p. 12

Fine-tune your cab driving techniques by clearing each of these unique mini-games.

## OPTIONS

p. 15

Use this mode to modify various settings of the game.

## RECORDS

p. 16

Here you can view the records and rankings for each of the game modes.

## SAVE & LOAD

p. 17

Use this mode to save or load game data or perform name entry for player files.



# ARCADE/ORIGINAL MODE

Both the Arcade and Original game modes have the same rules, content and menu. The only difference between these two modes is the course on which you play. After selecting either "ARCADE" or "ORIGINAL" from the mode selection menu, the following mode menu will be displayed. Use **↑** **↓** to select a mode and press **A** to enter your selection. Select "EXIT" or press **B** to return to the title screen.

## PLAY BY ARCADE RULES

Select this item to play according to the same rules as used in the Arcade version of Crazy Taxi. For details, see p. 9 – 11.

## WORK FOR 3 MINUTES

Play freely for three minutes. Note that in this mode there are no time bonuses (see p. 11) available.

## WORK FOR 5 MINUTES

Play freely for five minutes. Note that in this mode there are no time bonuses available.

## WORK FOR 10 MINUTES

Play freely for ten minutes. Note that in this mode there are no time bonuses available.

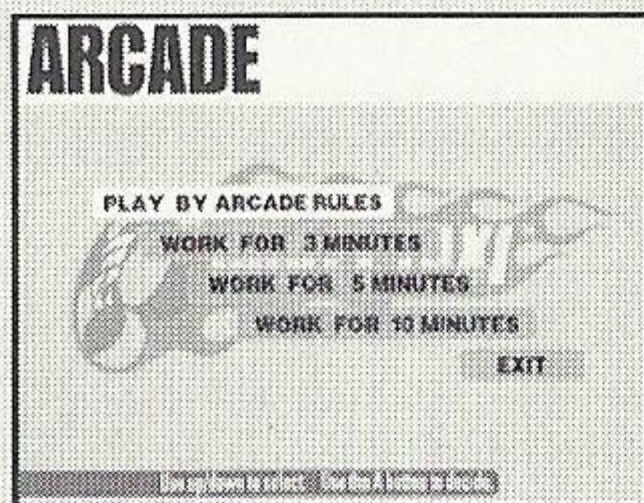

**Arcade Mode Menu**

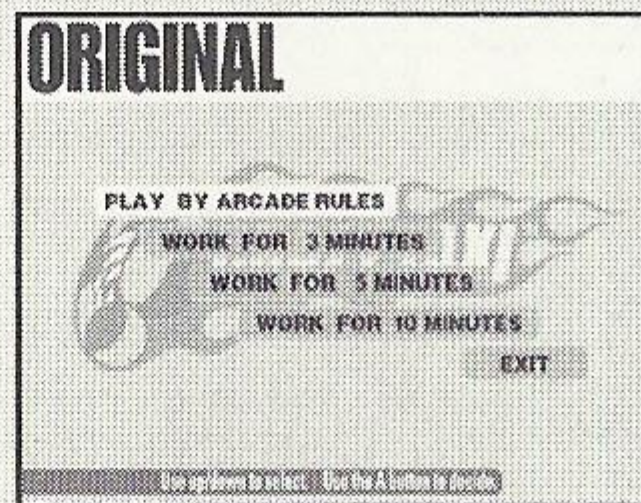

**Original Mode Menu**



# ARCADE/ORIGINAL MODE

## While driving a customer

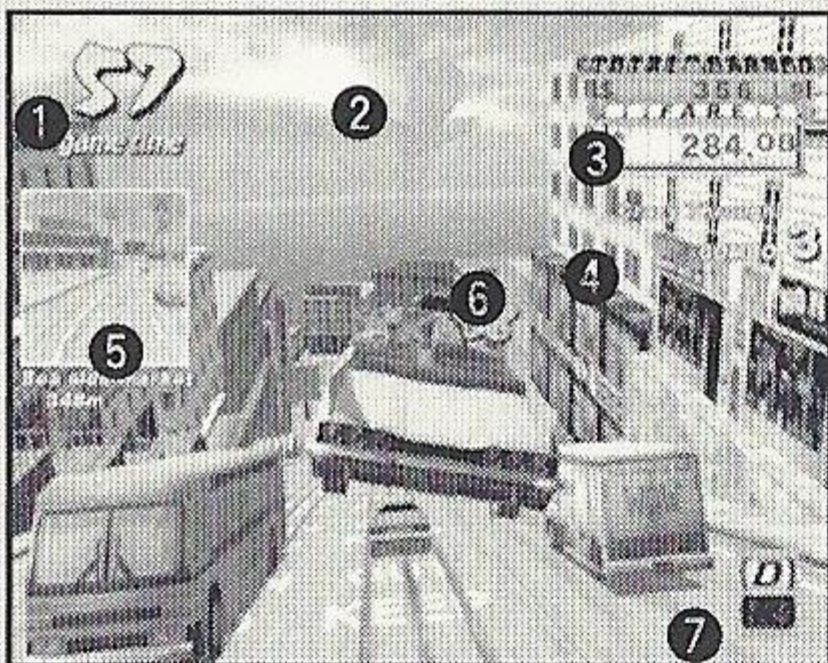

## At the destination

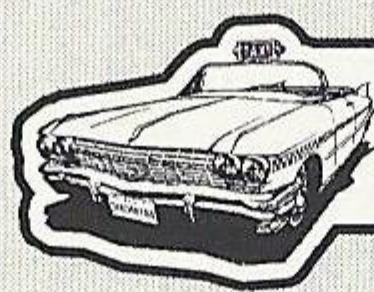

## GAME DISPLAY

- 1 Game Time:** Once this time limit counts down to **0** the game is over.
- 2 Directional Arrow:** This arrow shows the general direction of the destination.
- 3 Fares:** The top figure is the **Total Earned Fare** and is a total of all fares earned. The bottom figure is the **Fare** for the current customer, which includes the base fare plus any tips earned, and will be added to the total earned fare once the customer is delivered to their destination.
- 4 Crazy Manuevers & Combos:** All crazy maneuvers performed will appear here with a counter that tracks any successive combos made.
- 5 Destination and Distance Counter:** A picture of the destination location and a distance counter indicating the distance to the destination, is displayed as the customer gets into the cab. Press **X** to display this image while driving.
- 6 Customer Time Limit:** If this time limit reaches **0** before reaching the destination, the customer will jump out of the cab without paying their fare.
- 7 Gear Indicator:** Shows the gear, drive or reverse, currently selected.
- 8 Time Bonus Indicator:** Indicates the time bonus earned for arriving early at the destination. The time bonus is only available when playing the "PLAY BY ARCADE RULES" of the arcade and original modes (see p. 11 for details).
- 9 Ranking:** Shows your current ranking relative to the total rankings.

## Pausing the Game

To pause the game and display the pause menu while playing in the Arcade, Original or Crazy Box modes, press the Start Button. Use **↑** **↓** to select a menu item and press **A** to enter the selection. Press the Start Button to exit and continue playing.

**EXIT:** Select to exit the pause menu and continue playing.

**RETRY:** Select to restart the current game with the same driver in the same mode.

**MENU:** Select to exit the current game and return to the mode selection menu.

**VIBRATION:** If the vibration setting in the options menu is set to on, use **↑** **↓** to toggle this item ON/OFF. This item is only available when using a Jump Pack.

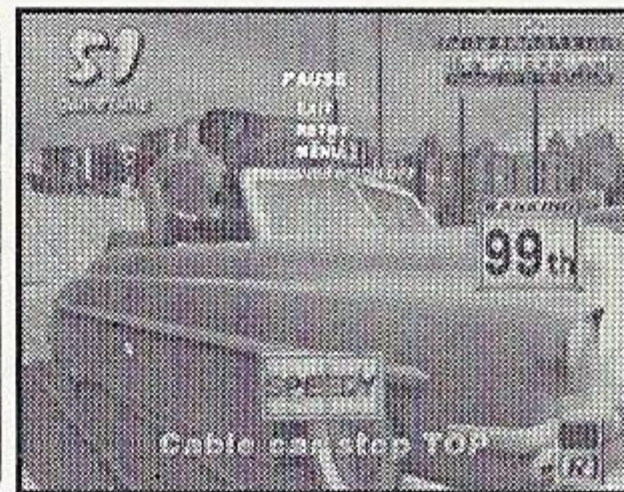



# ARCADE/ORIGINAL MODE

## DRIVER SELECTION

After selecting a game mode from either the Arcade or Original mode menu, the driver selection screen will be displayed.

Use ◀ ▶ to select a driver and press **A** to enter your selection. If the counter reaches 0 before you enter a selection, the currently displayed driver will automatically be selected.

## GAME OVER

Once the game time limit counts down to 0 the game is over and the results screen is displayed. If you can achieve a class ranking of **S**, the game ending and credits will play.

**CUSTOMERS** = The total number of customers delivered.

**TOTAL EARNED** = The total amount of money earned.

**CLASS** = This evaluation of your driving skills is based on a leveled assessment of your cumulative earnings. The available classes from the best down are **S**, **A**, **B**, **C**, **D**, **E** and **NO LICENSE**.

**RANKING** = This placement is your ranking relative to the saved data. If your score is too low to place, **OUT OF RANKING** will appear.

## SAVE MENU

Use this menu to save the results of the game to a VMU. Use ▲ ▼ to select where to save the data and press **A** to enter. If there are no player files set up in which to save data, select "**Register a new name**" and enter a new name to create a new file (see p. 17 for details).

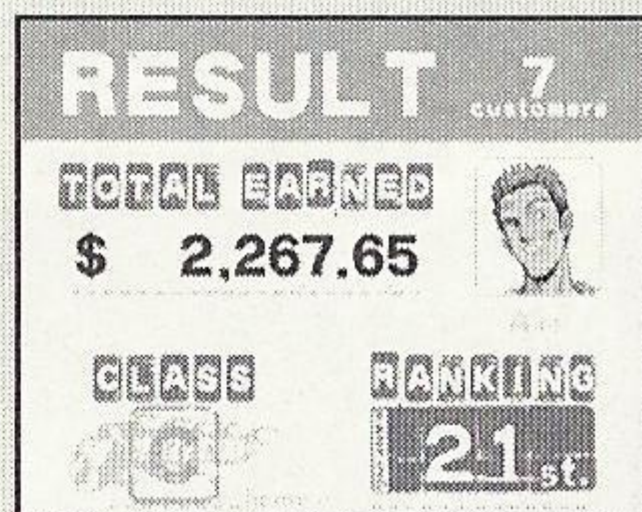
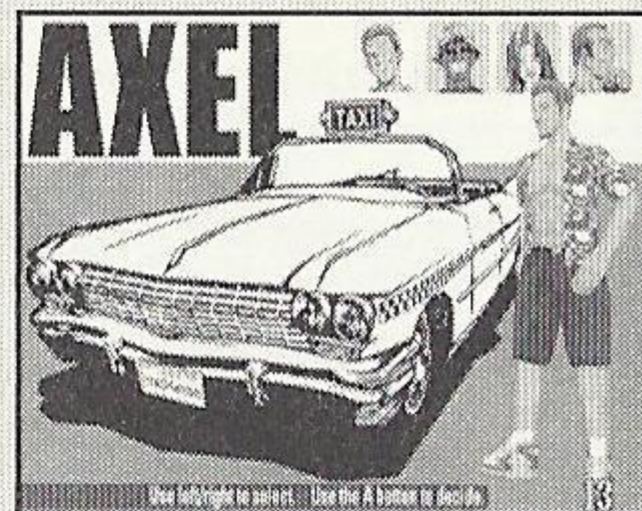

**NOTE:** Rankings are only displayed when playing the "PLAY BY ARCADE RULES" of the Arcade and Original modes.

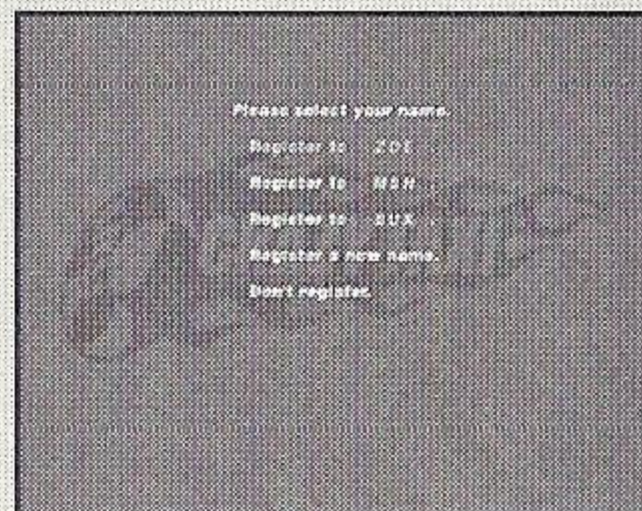



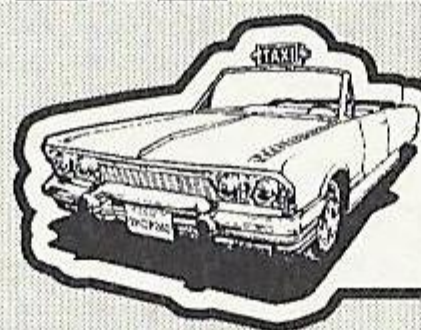

## GAME FLOW

### 1) Pick Up a Customer

Human characters located in the city with a "\$" icon over their heads indicate potential customers waiting for a taxi ride. To pick up a customer the player must brake the cab to a complete stop within the **stop zone** - the circular outline that appears around the customer. The customer will then automatically approach and get in the cab.

**NOTE:** While waiting for the customer to get into the cab the game clock will continue to run but control of the cab is not possible.



### 2) Drive to the Destination

Once the customer gets in the cab the following 3 items appear on the game display: the "Destination and Distance Counter" appears briefly to the left, the "Directional Arrow" appears at the center top and the "Customer Time Limit" appears over the customer's head. It is your job to travel in the direction indicated by the arrow and deliver the customer to their destination before the customer time limit reaches 0. Provided you reach the destination in time, you will be paid the base fare as well as any tips given by the customer in appreciation of "*crazy*" driving (see "Fare System" and "Tips" p. 10).



### 3) Drop Off the Customer

To drop off the customer, brake the cab to a complete stop within the green wall rimmed destination **stop zone**. Once stopped, the customer will automatically exit the cab and pay their fare (see p. 10) plus any tips received.

**NOTE:** While waiting for the customer to get out of the cab the game clock will continue to run but control of the cab is not possible.

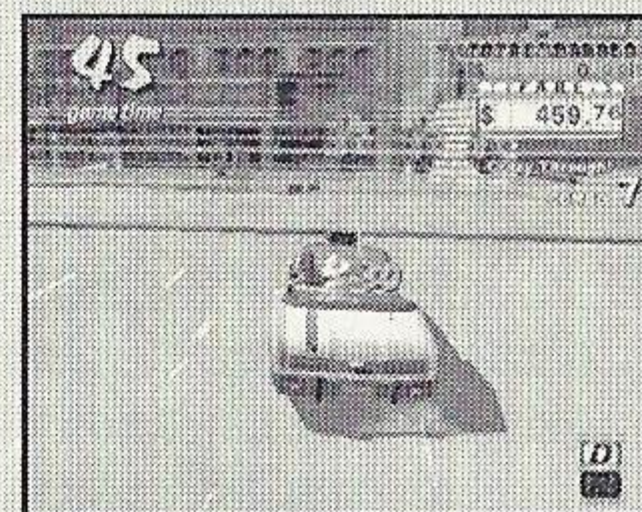

**Do your best to repeat the above 3 steps as many times as possible before the game time counter reaches 0 to earn loads of crazy money!**



# ARCADE/ORIGINAL MODE



The different colors of each customer "\$" icon indicate the relative distance to the destination while the size of the **stop zone** around the customer indicates the relative difficulty involved getting there.

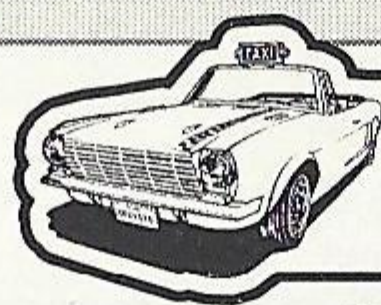

## \$ ICON COLOR VARIATIONS

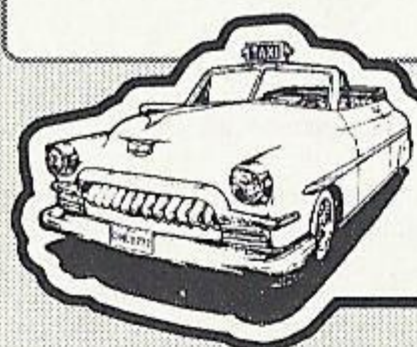
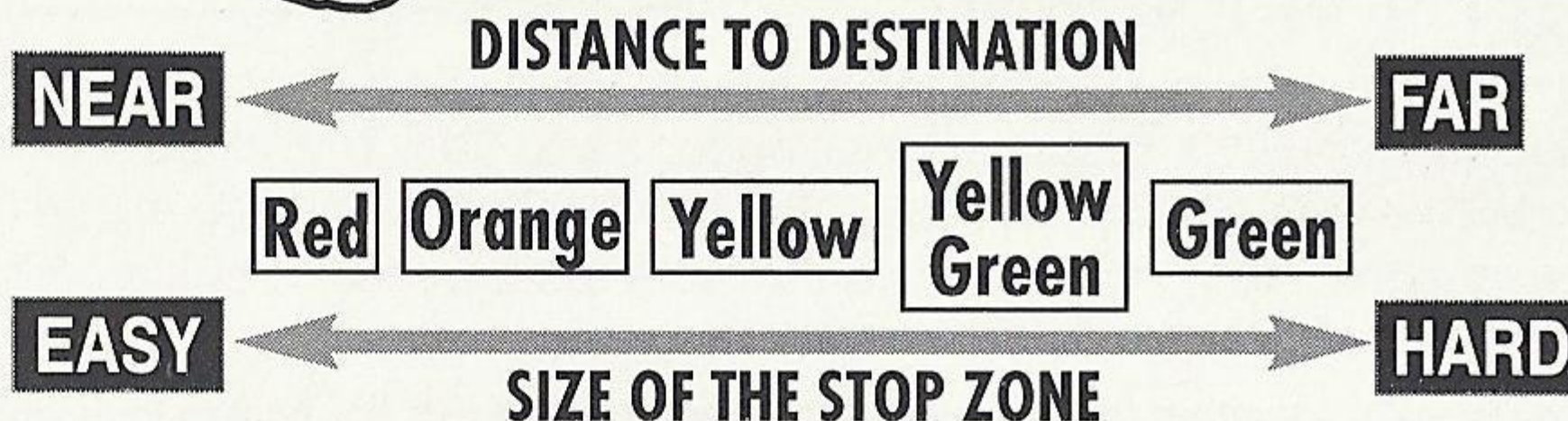

## FARE SYSTEM

### Time Limits and the Total Earned Fare

After getting into the cab, a number appears over the customer's head and begins to countdown. This is the customer time limit. If you are able to deliver the customer to their destination within this time limit you will be paid the **FARE**. This is then added to the **TOTAL EARNED FARE**. However, if you are unable to reach the destination before the counter reaches 0, the customer will jump out of the cab without paying.

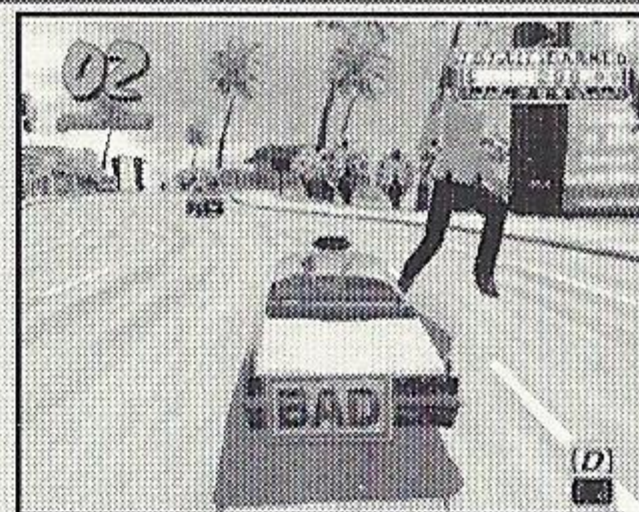

**Fares and Tips** The three types of fares that can be earned are as follows:

### BASE FARE

The base fare is calculated according to the distance of the destination. Once the customer gets in the cab, this amount will appear in blue under the total earned fare at the upper right of the game display.

### TIPS

Tips are awarded to the cabbie whenever "**crazy**" maneuvers are executed in the course of driving the customer to their destination. Each tip is added to the base fare as earned.

### BONUS FARE

When the cabbie arrives at the customer's destination, a bonus fare is converted from any time left over from the initial customer time limit. This is added to the base fare just before payment.



# ARCADE/ORIGINAL MODE

## EARNING TIPS

If the cabbie is able to "please" the customer by performing any of the following crazy maneuvers while delivering the customer to their destination they will be rewarded monetarily with tips. All tips are added to the base fare and then to the total earned fare upon arrival at the destination.

## CRAZY JUMP

Use jump ramps or other similar elevated obstacles to become airborne.



## CRAZY DRIFT

Sustain a sliding drift of the cab while turning.

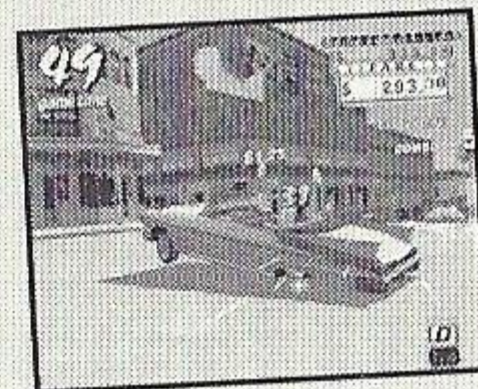

## CRAZY THROUGH

Cut in close to the other vehicles that you pass on the roads without hitting them.

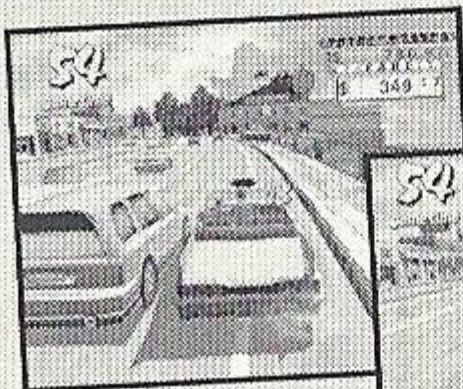

## COMBOS

If you are able to earn tips in succession, a running tally of the number of combos appears on the right of the display and continues until you collide with another vehicle. The more combos accumulated, the higher the tip value becomes, so do your best to rank up consecutive combos whenever and wherever possible! If you make a mistake or collide with another vehicle, the combo counter resets to zero.



## TIME BONUS

When the cabbie delivers the customer to their destination, any leftover time from the customer time limit is converted into a **Time Bonus**, which is then added to the game time. The faster the cabbie arrives at the destination, the higher the bonus time awarded will be. The available time bonuses are:

**SPEEDY**

+5 seconds  
(Green)

**NORMAL**

+2 seconds  
(Yellow)

**SLOW**

No Bonus  
(Red)

**BAD**

Appears when the customer jumps out of the cab without paying (Purple)

**NOTE:** Time Bonuses are only available in the "PLAY BY ARCADE RULES" of the arcade and original modes.



# CRAZY BOX MODE

Use the various mini-games available in this mode to develop and improve your cab driving skills.

Use **↑ ↓ ← →** to select a mode and press **A** to enter your selection. Select **"EXIT"** or press **B** to return to the title screen.

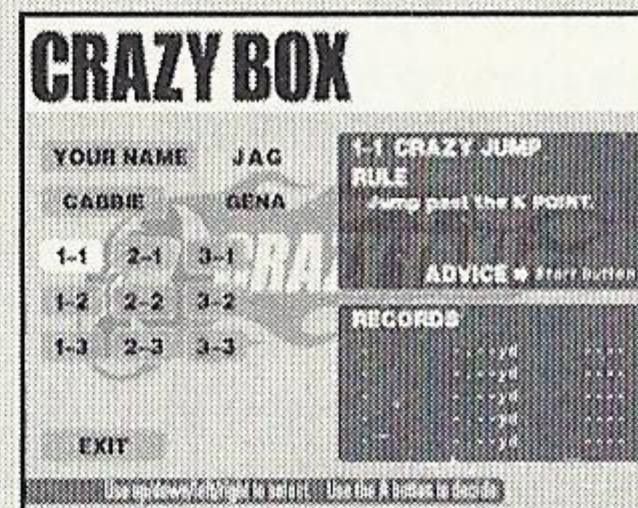

## PLAYER FILE SELECTION

First, use **← →** to select the name that represents your player file. If there are no player files available, select **"NEW ENTRY"** and press **A** to display the name entry screen. Enter a new name to create a new player file (see p. 17 for details).

## CABBIE SELECTION

Use **← →** to select a cabbie and press **A** to enter your selection.

## MINI-GAMES

Use **↑ ↓ ← →** to select a mini-game to play from among the displayed options. The rules and current rankings for the selected mini-game will be displayed to the right. Press the Start Button to display an advice box with tips on how to successfully complete the selected mini-game. Press the Start Button again to return to the Crazy Box selection menu. To play the selected game, press **A**.

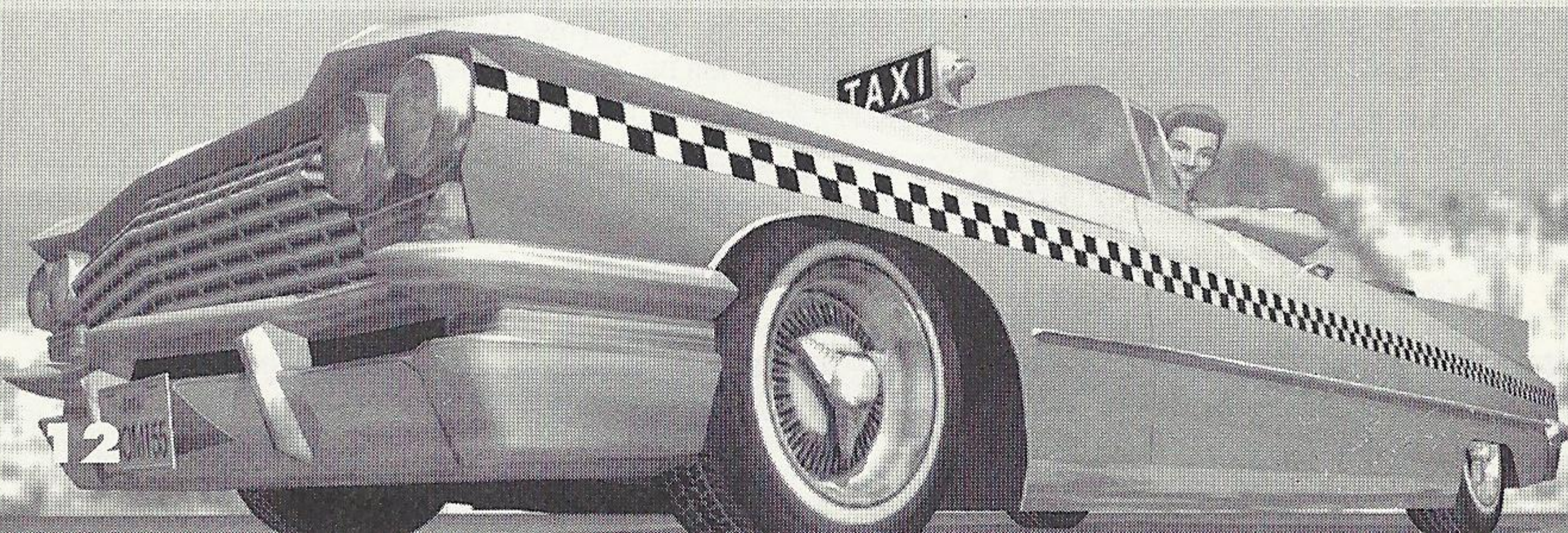



The following mini-games are available at the start of play in the Crazy Box mode:

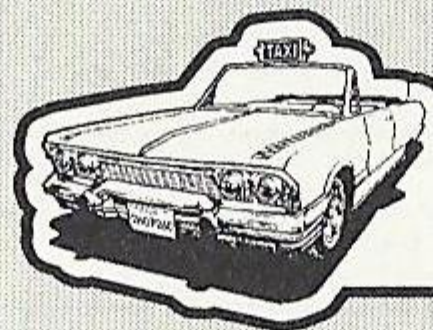

## MINI-GAMES

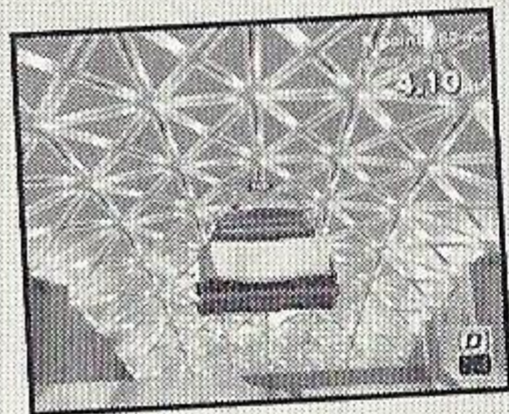

**1-1**

### CRAZY JUMP

**GOAL**

Jump the cab off the jump ramp and land past the K point.

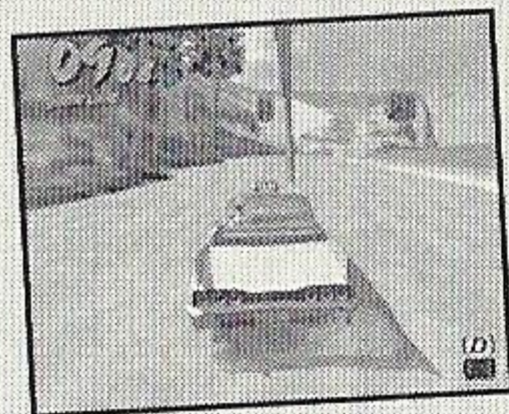

**1-2**

### CRAZY FLAG

**GOAL**

Reach the flag located directly behind the cab on the other side of the beach within the allotted time limit.



**1-3**

### CRAZY BALLOONS

**GOAL**

Burst all the balloons on the field within the allotted time limit.

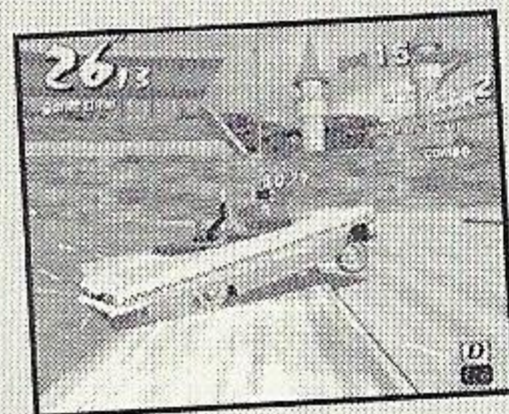

**2-1**

### CRAZY DRIFT

**GOAL**

Earn more than 15 total combos using the Crazy Drift within the allotted time limit.



# CRAZY BOX MODE

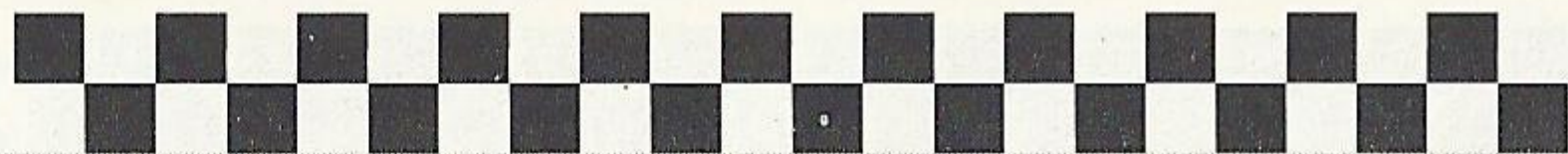

**2 - 2**

**GOAL**

## CRAZY TURN

Deliver the customer to their destination within the allotted time limit.



**2 - 3**

**GOAL**

## CRAZY BOUND

Deliver the customer to their destination within the allotted time limit without falling into the ocean.



**3 - 1**

**GOAL**

## CRAZY RUSH

Deliver all five customers to their destinations within the allotted time limit.

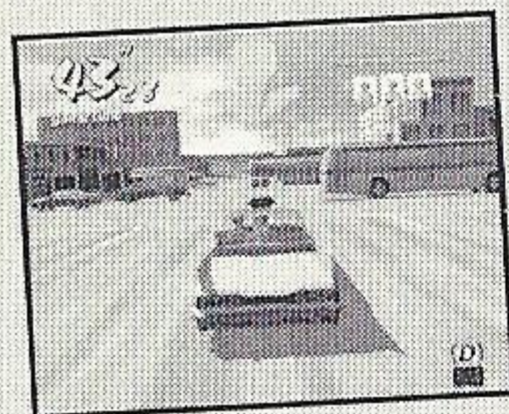

**3 - 2**

**GOAL**

## CRAZY JAM

Deliver all three customers to their destinations, through heavily congested traffic, within the allotted time limit.

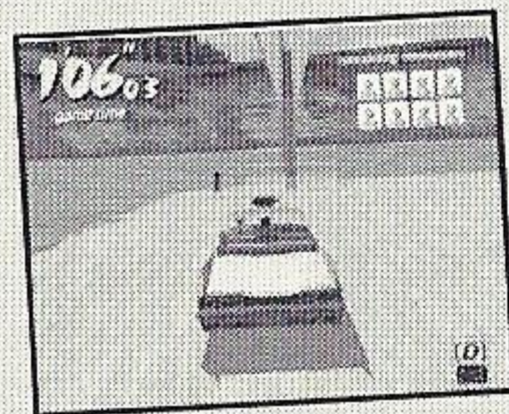

**3 - 3**

**GOAL**

## CRAZY POLE

Deliver all the customers to their destinations within the allotted time limit.



# OPTIONS

From the options menu it is possible to modify the following game settings.

Use the **↑** **↓** to select an item and **←** **→** to modify the setting. Select **"EXIT"** or press **B** to return to the mode selection menu. The settings available for modification are as follows:

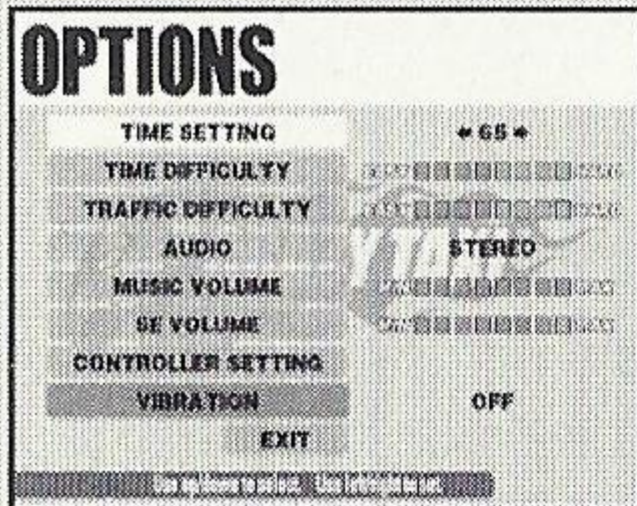

## TIME SETTING

Adjust the game time limit setting of the Arcade and Original modes for **"PLAY BY ARCADE RULES"** mode play.

## TIME DIFFICULTY

Adjust the difficulty level of the game time setting of the Arcade and Original modes for **"PLAY BY ARCADE RULES"** mode play.

## TRAFFIC DIFFICULTY

Adjust the difficulty level of the traffic setting of the Arcade and Original modes for **"PLAY BY ARCADE RULES"** mode play.

## AUDIO

Set the preferred sound output to either **MONO** or **STEREO**.

## MUSIC VOLUME

Adjust the volume setting for the background music.

## SE VOLUME

Adjust the volume setting for the sound effects (SE).

## TIME SETTING

Press **A** to display the controller settings screen and then select a controller setting type for the Dreamcast Controller or the Rally Wheel.

## VIBRATION

Set to **"ON"** when using a Jump Pack while playing. This setting is only activated when a Jump Pack is inserted into Expansion Socket 2 of the Dreamcast Controller.

**NOTE:** Whenever you modify the options settings, the data will automatically be saved to the VMU when you exit the options menu.



# RECORDS

Here you can view all the records and rankings earned in every mode of the game. Use the **↑** **↓** to select an item and press **A** to enter your selection. Select "EXIT" or press **B** to return to the mode selection menu.

**TOTAL RECORDS** Select to view all the records for each player in all modes.

**\_\_\_ RECORDS** Select a player file from among the displayed options to view the individual records for that player.

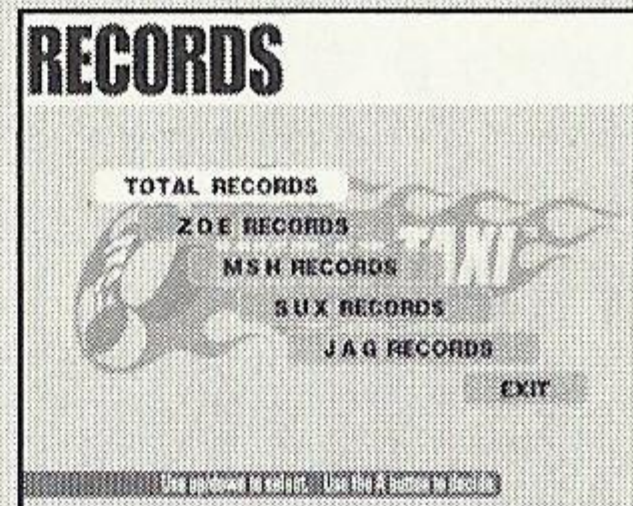

## RECORDS MENU

Use **↑** **↓** to select a mode from the three options displayed on the left and **←** **→** to move forwards and backwards among pages. Select "EXIT" and press **A** to return to the Records menu.

**AC**

**Arcade Mode Records**

**OR**

**Original Mode Records**

**CB**

**Crazy Box Mode Records**

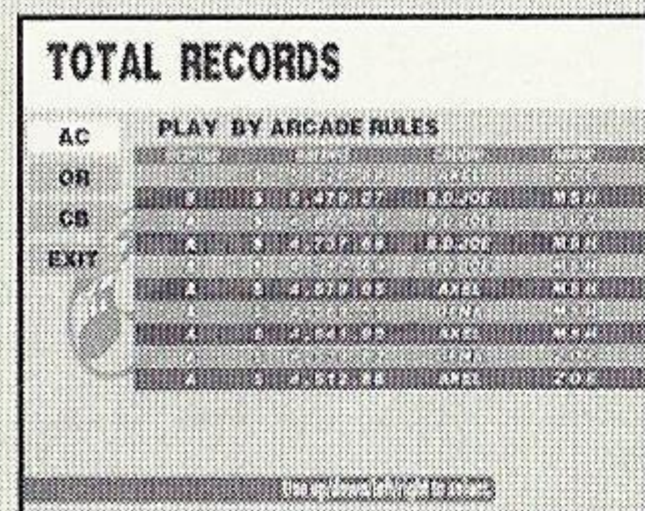

**TOTAL RECORDS**

**license:** The license class awarded (appears only with AC/OR records).

**earned:** Total amount of money earned (appears only with AC/OR records).

**cabbie:** The cab driver used.

**name:** The name of the player who earned this record (appears only with the TOTAL RECORDS).

**ranking:** The overall ranking for each successful clear (appears only with the CB records).

**score:** The actual score achieved (appears only in the CB records).

**date:** The date when the record entry was made (appears only with the \_\_\_ records).



# SAVE & LOAD

Here you can save and load game data, enter a name to create a new player file or modify the name of a current player file. Use the **↑** **↓** to select an item and press **A** to enter your selection. Select **EXIT** or press **B** to return to the mode selection menu.

## SAVE

Select to save all the current game settings and records to the VMU.

## LOAD

Select to load previously saved data from the VMU.

## ENTER NAME

Select to enter a new name or create a new player file. See below for details on how to enter a name.

## DELETE NAME

Select to delete a player file. Use **↑** **↓** to select a file and press **A**. When the deletion confirmation window appears, select **yes** to delete the file or **no** to cancel the deletion and return to the Save & Load menu.

## MODIFY NAME

Select to edit the name of a player file. Use **↑** **↓** to select a file and press **A**. See below for details on how to enter a name.

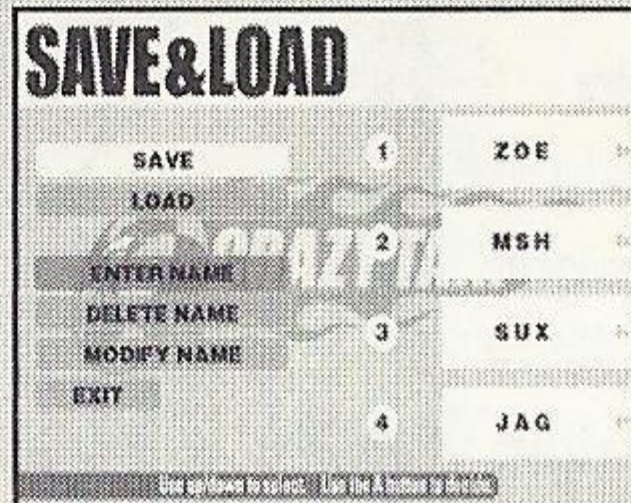

## NAME ENTRY

Up to three characters can be used for each name entered to create a player file. Use **↑** **↓** to select a letter and **←** **→** to move the cursor. Press **A** to enter the name.

Press **B** to exit the name entry without entering a name.

A total of four player files can be created and maintained for saving game data.

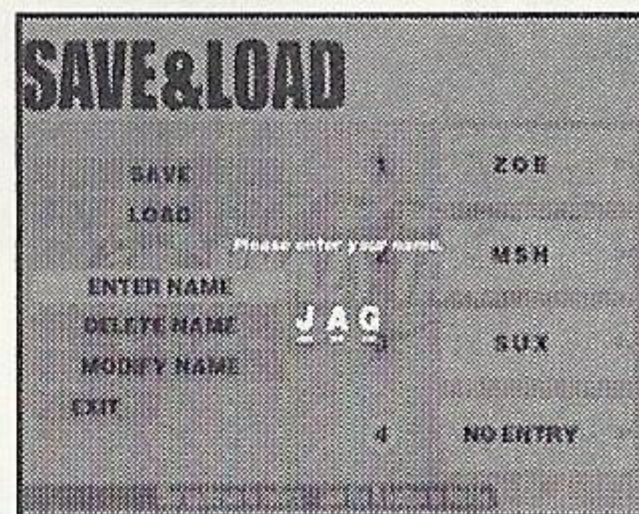

## NAME ENTRY



# CABBIES

## AXEL

Age

21

Sex

Male

Height

6' 0"

Weight

158

License **1NOM155** = "I no miss"

Plate # Meaning: "I don't make mistakes"



This wild guy is known to have a hot and quick temper. His only reason for becoming a taxi cab driver is that he considers being a cabbie the "coolest" profession. Axel always shows his customers a good time while driving his 60's era classic cab, earning big tips in the process! For him, cab driving is the ultimate career.

When he isn't working, Axel is usually trying to pick-up women, jamming with his punk band (bass and vocals) or participating in board sports like surfing or snowboarding. That said however, Axel's overly freewheeling nature causes his band members to come and go on a regular basis and prevents him from maintaining decent relationships with women. Oh well, what's a guy to do? While he isn't perfect, his openhearted personality and naturally cheerful nature means he kind of grows on you. His most redeeming quality is that he is especially gifted at mediating whenever there is trouble or fighting amongst his many friends.

## GENA

Age

23

Sex

Female

Height

5' 7"

Weight

???

License **5EXY515** = "Sexy Sis"

Plate # Meaning: You know what it means!

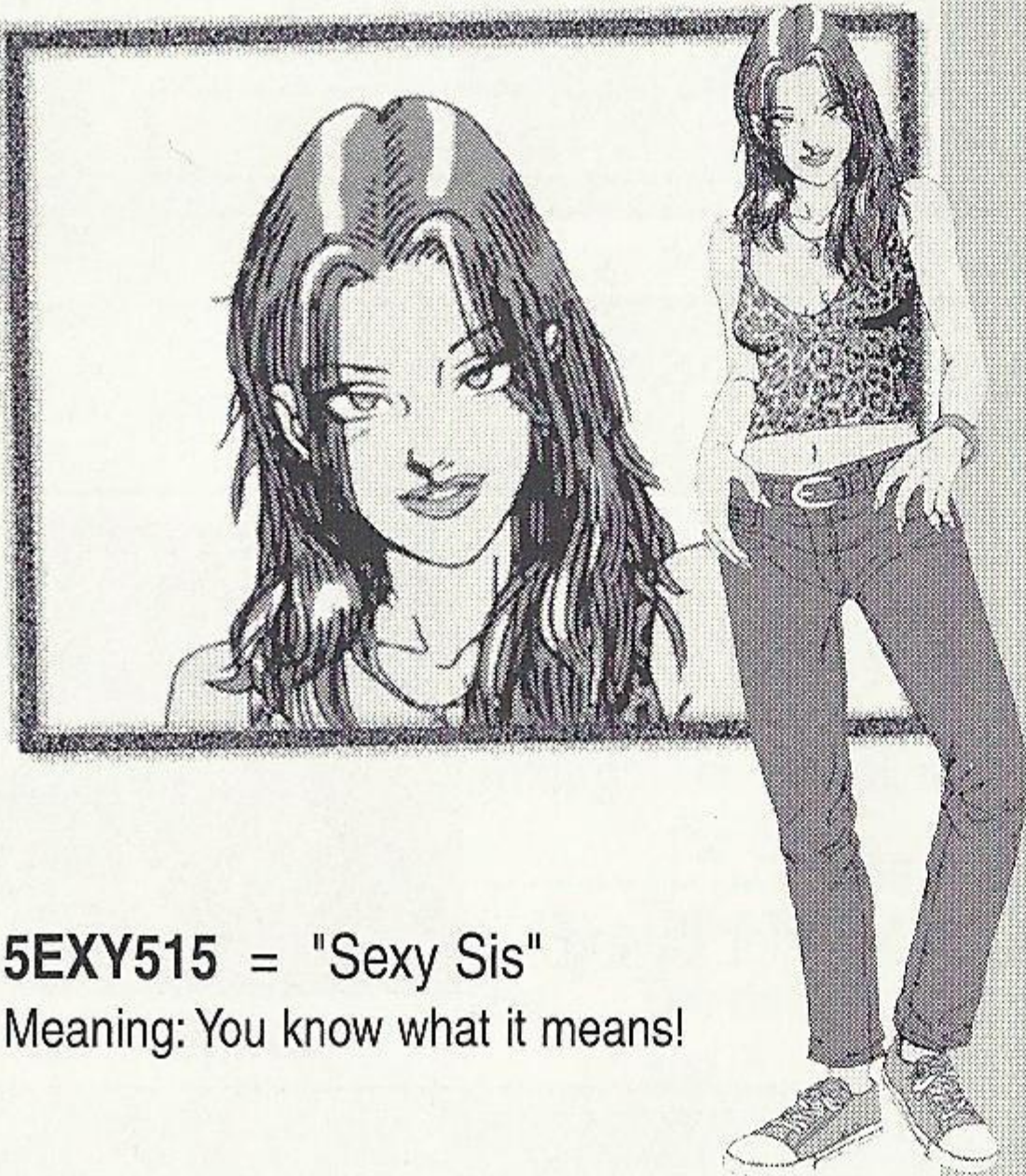

If Gena could be described in two words, without a doubt those words would be "cool & sexy". With a strong passion for cars, her reason for becoming a cab driver is simply, "Because I get to race around in my car all day!" While she's not so concerned with amusing her customers per se, she sure is timely. When asked if she'd be happier as a race car driver she just laughs and replies, "But it is such a rush to race through the traffic-laden streets...I could never give this up!" When Gena is not working in her beloved cab, she can usually be found working on it. In fact, she spends nearly all her time and money performing extensive tune-ups, maintenance and cleaning. It is no surprise that most of the money she earns goes straight into her cab.

Despite her cab fixation, men are attracted to Gena's beauty. But she simply turns her nose up at any man who dares try to woo her. Clearly the sole object of her affection is her one and only cab!



# CABBIES

Always friendly & cheerful... that's B.D. Joe. For him, driving a cab is a line of work in which he can "make people happy". Happiest when he can bring a smile to the face of customers, B.D. is a master of both driving and conversational techniques. Even when not driving his cab B.D. Joe is well known as an accomplished performance artist. He can throw together some lids and drum cans, and using a pair of drumsticks, can blow you away with his musical prowess. His rhythms sound so fine they put the "professional" musicians to shame. His talent is such that he is often asked why he doesn't perform professionally. But he just laughs and says, "Making people smile is reward enough for me besides cabbing is too much fun to give up!"

Lately B. D. Joe has taken up card tricks...why you may ask? Because by doing so he can make anyone's day anytime, anywhere.

Gus is a handsome (in a melancholy sort of way) drifter who typifies the term "cool". He holds the unique distinction of being the originator of the "crazy" style. In his youth, Gus was a wild and uncontrollable hooligan, selfish to a fault. He hated to lose and always had to be # 1 at any and all cost. With a strong fascination for all things new, Gus was naturally drawn to that one unique trend that was totally cool. With a knack for getting into something before it became popular, in the days when he didn't even own a car he was riding in a normal taxi when he had a flash of inspiration and bought an old junked out 1955 jalopy. Thus began the crazy taxi trend.

When Gus isn't driving, he can usually be found playing cards. When the working day ends he meets with his poker buddies (whose members change nightly) to while away the time playing poker, blackjack and baccarat. A benefit of his gambling is that Gus has come to understand the ways of strategy, thereby mellowing his former desire to win at all costs. Learning the why and how of losing has made Gus a better person.

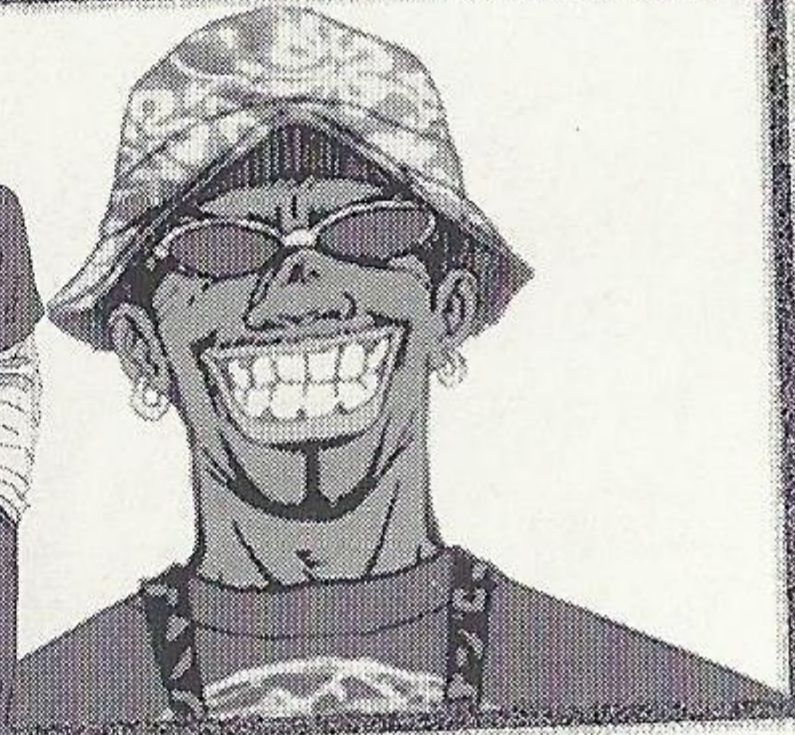
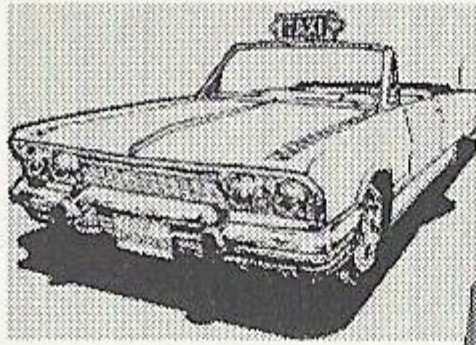

**B.D.  
JOE**

**Age**

25

**Sex**

Male

**Height**

5' 9"

**Weight**

165

**License**

**Plate #**

**2HOP260** = "To hop to go"

Meaning: "Always ready to get crazy"

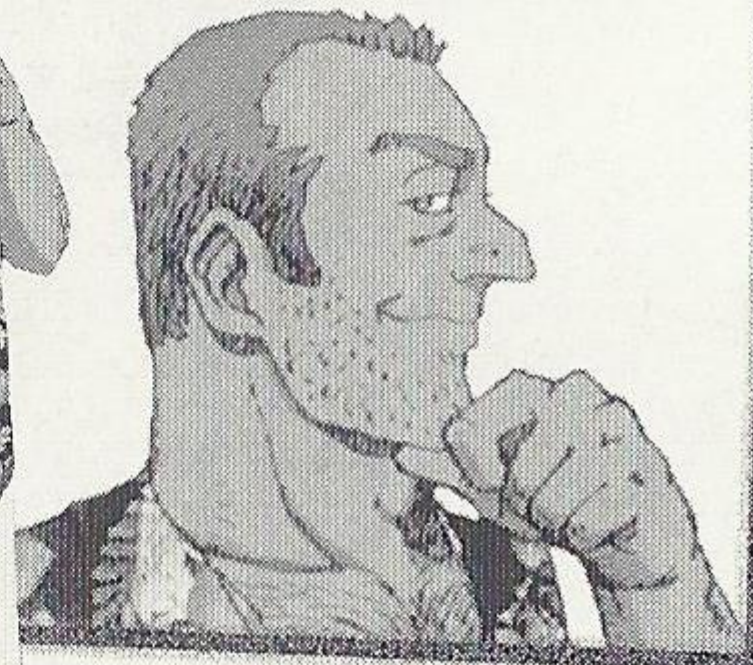
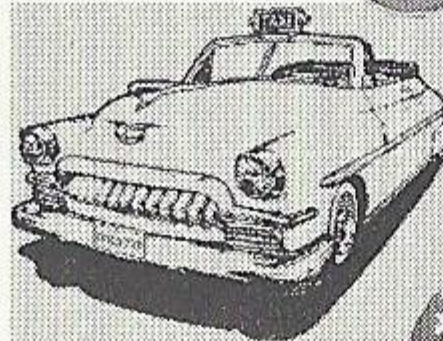

**GUS**

**Age**

42

**Sex**

Male

**Height**

5' 8"

**Weight**

187

**License**

**Plate # ONLY777** = "Only 777"

Meaning: "Only aim for the big jackpot"



# CUSTOMERS

Let's meet a few of the many customers you'll find throughout the city awaiting a crazy taxi ride.



## Cindy

This young pretty college student is a psychology major who just loves junk food!



## Rachel

Currently working as a hospital volunteer, this young woman dreams of becoming a doctor someday.

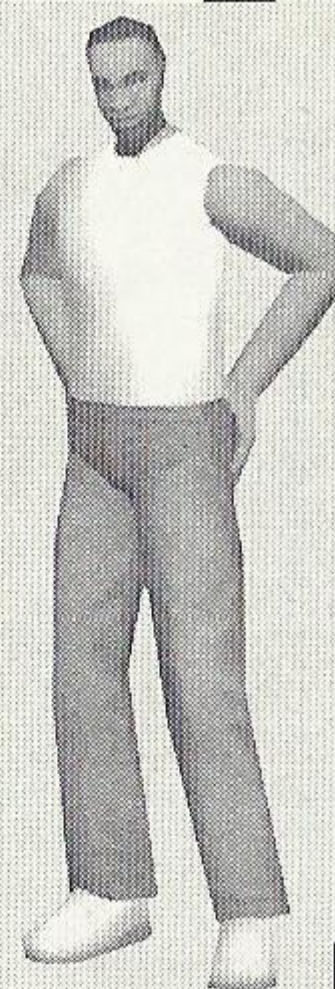

## Dan

A graduate student of economics, Dan is in the process of writing his thesis on the economical impact of the fashion industry on world markets.

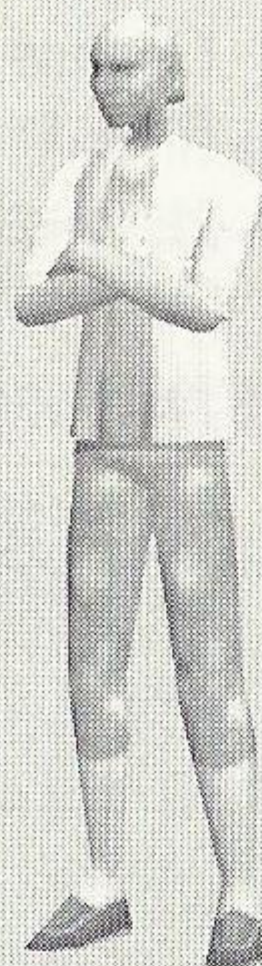

## Grandma J

Keep your eyes peeled for this feisty ol' lady! Those loud and colorful pajamas on Ms. Jessica are sure hard to miss.



## Biff

A baseball fanatic who never misses a game, Biff travels by helicopter to watch his favorite baseball team in action whenever they are playing away games.

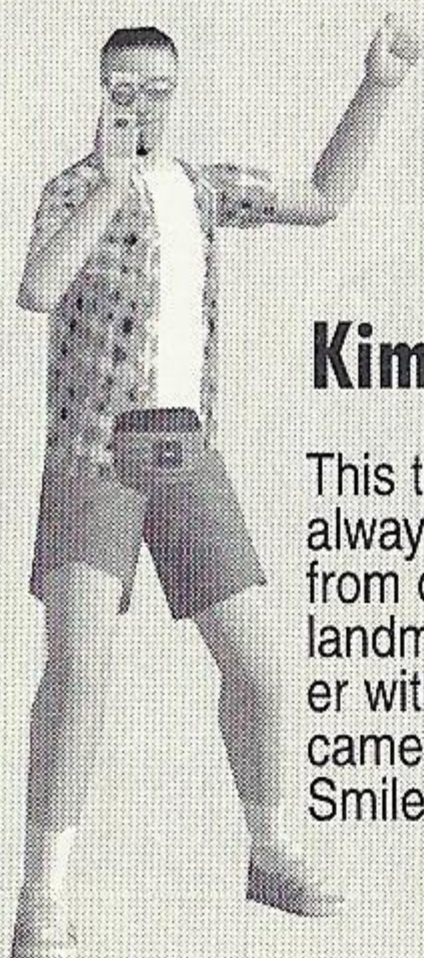

## Kim

This tourist is always running from one famous landmark to another with a video camera in hand. Smile!



## Buzz

A hard-core loving punk rocker who has a habit of suddenly appearing in the most unexpected of places!



## Pierre

A hopelessly romantic young man who spends all his time and money chasing women...another day another date.





# MANUAL CREDITS



The following credits list the staff responsible for the localization marketing and manual production for the U.S. version of Crazy Taxi. Credits for the original development staff of the game are listed in the credits of the game itself.

## **SEGA of America Product Development**

### **Localization Producer**

Osamu Shibamiya

### **Test Lead**

Arnold Feener

### **Assistant Test Leads**

Gabrielle Brown

Rick Ribble

## **Marketing**

### **Product Marketing**

Rick Naylor

John Golden

### **Public Relations**

Heather Hawkins

### **Creative Services**

Bob Schonfisch

Angela Santos

## **SEGA of Japan Manual Production**

### **Writer/Translator/DTP**

Monika Hudgins

### **Design**

Takashi Nishimura

### **Writer**

Fumiaki Tomura

### **Supervisor**

Kaoru Ichigozaki

## **Special Thanks**

Lindsi Kimizuka

Todd Slepian















**\*THIS LIMITED WARRANTY IS VALID FOR U.S. AND CANADIAN SEGA DREAMCAST SOFTWARE MANUFACTURED FOR SALE IN AND PURCHASED AND OPERATED IN THE UNITED STATES AND CANADA, ONLY!**

## **Limited Warranty**

Sega of America, Inc. warrants to the original consumer purchaser that the Sega Dreamcast GD-ROM shall be free from defects in material and workmanship for a period of 90-days from the date of purchase. If a defect covered by this limited warranty occurs during this 90-day warranty period, Sega will replace the defective GD-ROM or component free of charge. This limited warranty does not apply if the defects have been caused by negligence, accident, unreasonable use, modification, tampering or any other causes not related to defective materials or workmanship. Please retain the original or a photocopy of your dated sales receipt to establish the date of purchase for in-warranty replacement.

## **WARRANTY REPAIRS**

IF YOUR SEGA DREAMCAST GD-ROM DISK IS DEFECTIVE OR HAS BEEN DAMAGED, DO NOT RETURN IT TO SEGA. RETURN THE DISK, IN ITS ORIGINAL PACKAGING, ALONG WITH YOUR ORIGINAL SALES RECEIPT TO THE RETAILER FROM WHICH THE SOFTWARE WAS ORIGINALLY PURCHASED. Sega of America cannot offer credit or exchanges for merchandise purchased through your retail store.

If you have questions about the warranty service, contact Sega Consumer Service Department at <http://www.sega.com> or 1-800-USA-SEGA. Instructions en français, téléphoner au: 1-800-872-7342.

## **OUT OF WARRANTY REPAIRS AND REPAIRS AFTER EXPIRATION OF WARRANTY**

If your Sega Dreamcast GD-ROM requires repairs after the termination of the 90-day limited warranty period, you may contact Sega at the web site or 800 number listed above for instructions on receiving technical support and repair service.

## **LIMITATIONS ON WARRANTY**

Any applicable implied warranties, including warranties of merchantability and fitness for a particular purpose, are hereby limited to 90-days from the date of purchase and are subject to the conditions set forth herein. In no event shall Sega of America, Inc., be liable for consequential or incidental damages resulting from the breach of any express or implied warranties. The provisions of this limited warranty are valid in the United States only. Some states do not allow limitations on how long an implied warranty lasts, or exclusion of consequential or incidental damages, so the above limitation or exclusion may not apply to you. This warranty provides you with specific legal rights. You may have other rights which vary from state to state.

## **ESRB RATING**

This product has been rated by the Entertainment Software Rating Board. For information about the ESRB rating, or to comment about the appropriateness of the rating, please contact the ESRB at 1-800-771-3772.

Sega is registered in the U.S. Patent and Trademark Office. Sega, Dreamcast, the Dreamcast logo and Crazy Taxi are either registered trademarks or trademarks of SEGA Enterprises, Ltd. All Rights Reserved. This game is licensed for use with the Sega Dreamcast system only. Copying and/or transmission of this game is strictly prohibited. Unauthorized rental or public performance of this game is a violation of applicable laws. ©SEGA ENTERPRISES, LTD., 1999. Sega of America, P.O. Box 7639, San Francisco, CA 94120. All rights reserved. Programmed in Japan. Made and printed in the USA.

Product covered under one or more of the following: U.S. Patents No's: 5,460,374; 5,627,895; 5,688,173; 4,442,486; 4,454,594; 4,462,076; Re. 35,839; Japanese Patent No. 2870538 (Patents pending in U.S. and other countries); Canadian Patent No. 1,183,276.



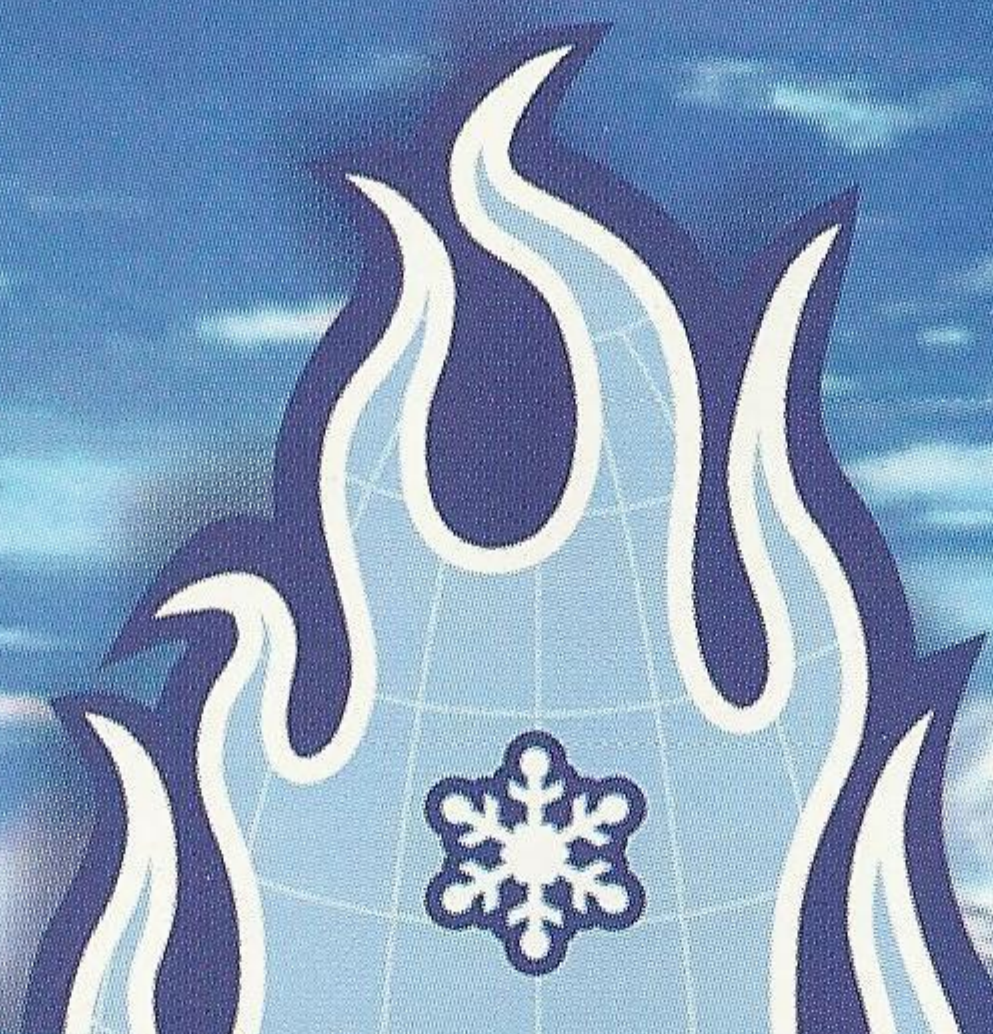

# RIPPIN' RIDERS

SNOWBOARDING

